

# ELECTRIC HYDRAULIC SCISSOR LIFT TABLE, PARTIAL STAINLESS STEEL - EHLT-2448-1-43-PSS

APPROX WEIGHT: 591.86 lbs.  
 DOES NOT INCLUDE WEIGHT OF POWER OR PACKAGING!!!

\*\*\* ANY ADDITIONS, DELETIONS, OR OMISSIONS MUST BE CORRECTED ON THIS DRAWING AS THIS DRAWING WILL BE CONSIDERED ALL INCLUSIVE \*\*\*  
 ALL GRAPHICS PROVIDED ARE FOR REFERENCE ONLY. IF CERTAIN DIMENSIONS ARE CRITICAL PLEASE VERIFY THOSE DIMENSIONS WITH YOUR SALESPERSON

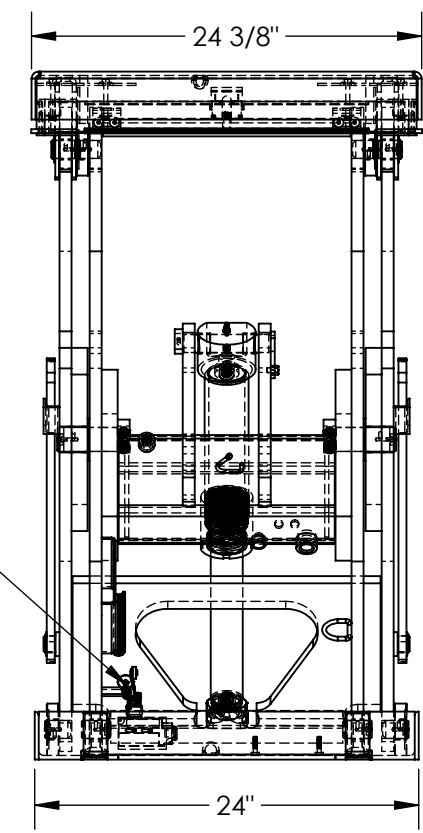
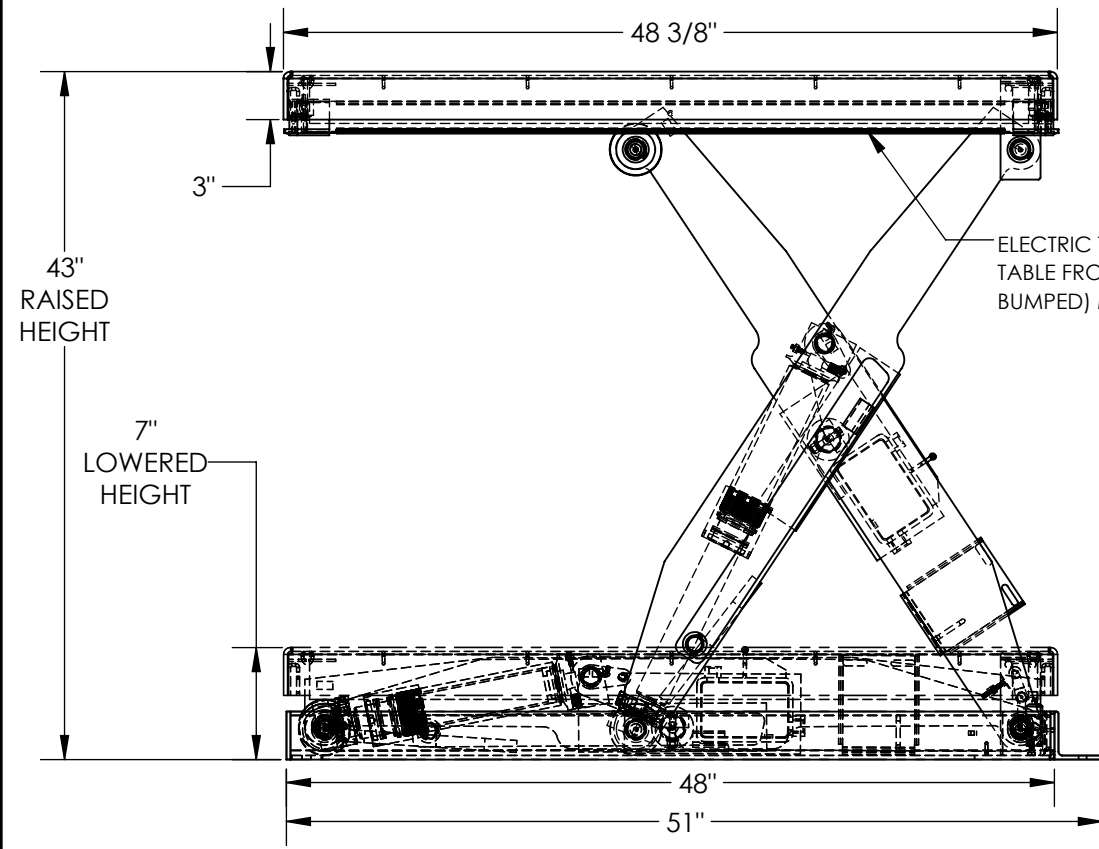

DIMENSION TOLERANCE ± 1/4"

## STANDARD FEATURES

MODEL NUMBER IS EHLT-2448-1-43-PSS  
 PLATFORM WIDTH IS 24 3/8"  
 PLATFORM LENGTH IS 48 3/8"  
 OVERALL LENGTH IS 51"  
 PLATFORM RAISED HEIGHT IS 43"  
 PLATFORM LOWERED HEIGHT IS 7"  
 TABLE CAPACITY (EVENLY DISTRIBUTED)  
 LOAD IS 1,000 LBS  
 CONTROLS HAND PENDANT ON 8' CORD  
 SAFETY MAINTENANCE PROPS, DISPLACEMENT  
 STYLE CYLINDERS INSTALLED ROD DOWN  
 EMERGENCY SAFETY STOP HYDRAULIC FUSES  
 IN ALL CYLINDER. UNITS HAVE 2' TEST LEAD  
 AND PIG TAIL  
 FRAME AND DECK - MILL FINISH 304 STAINLESS STEEL  
 GREASABLE PINS AND ROLLERS - 17-4 STAINLESS STEEL  
 SCISSOR LEGSET - CARBON STEEL WITH  
 TOUGH BAKED IN POWDER COATED WHITE FINISH

## PLEASE CIRCLE SPECIFICATIONS:

POWER	AC	<del>DC (12V)</del>	<del>AIR/OIL</del>
MOTOR VOLTAGE	<del>115</del>	<del>208</del>	<del>230</del> 460
DEDICATED CIRCUIT REQUIRED 60Hz			
MOTOR PHASE	<del>SINGLE</del>	THREE	
CONTROL	HAND	<del>FOOT</del>	

FOR INTERNAL USE ONLY PROJECT SIGN OFF	
SALES	
ENG.	
FAB.	
POWER	

DECK TOLERANCE ± 1/2"  
 TABLE HEIGHT TOLERANCE ± 1/2"  
 DECK FLATNESS ± 1/4"

## SPECIAL FEATURES NONE

**APPROVAL**

I, THE UNDERSIGNED, AGREE THAT THE PRODUCT AS REPRESENTED SATISFIES DESIGN AND DIMENSION REQUIREMENTS. I ALSO ACKNOWLEDGE MY DUTY TO CONFIRM PRODUCT AND INSTALLATION COMPLIANCE WITH ALL APPLICABLE FEDERAL, STATE AND LOCAL REGULATIONS AND STANDARDS.  
**ANY MODIFIED UNITS ARE NON-RETURNABLE**  
 As drawn     As marked

Signed: \_\_\_\_\_ Date: \_\_\_\_\_  
 Printed Name: \_\_\_\_\_  
**LEAD TIME WILL START UPON RECEIPT OF SIGNED APPROVAL DRAWING**

DISTRIBUTOR'S NAME:		P.O.#
VESTIL MANUFACTURING		X
DRAWN BY: BCN		W.O.#
DATE: 8/30/2017		X
REFERENCE: X	SCALE: 1:12	SALES: X
QUOTED LEAD TIME: X	QUOTE # X	FILE NAME:
		24-007-005-001

# ELECTRIC HYDRAULIC SCISSOR LIFT TABLE, PARTIAL STAINLESS STEEL - EHLT-2448-2-43-PSS

APPROX WEIGHT: 599.56 lbs.  
 DOES NOT INCLUDE WEIGHT OF POWER OR PACKAGING!!!

\*\*\* ANY ADDITIONS, DELETIONS, OR OMISSIONS MUST BE CORRECTED ON THIS DRAWING AS THIS DRAWING WILL BE CONSIDERED ALL INCLUSIVE \*\*\*  
 ALL GRAPHICS PROVIDED ARE FOR REFERENCE ONLY. IF CERTAIN DIMENSIONS ARE CRITICAL PLEASE VERIFY THOSE DIMENSIONS WITH YOUR SALESPERSON

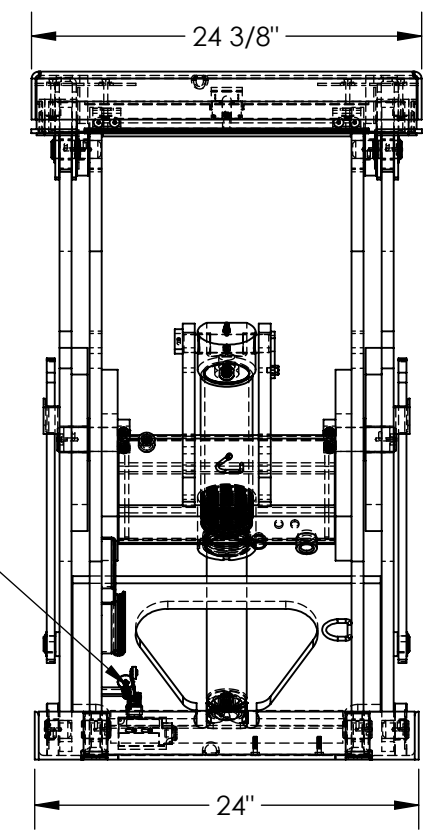
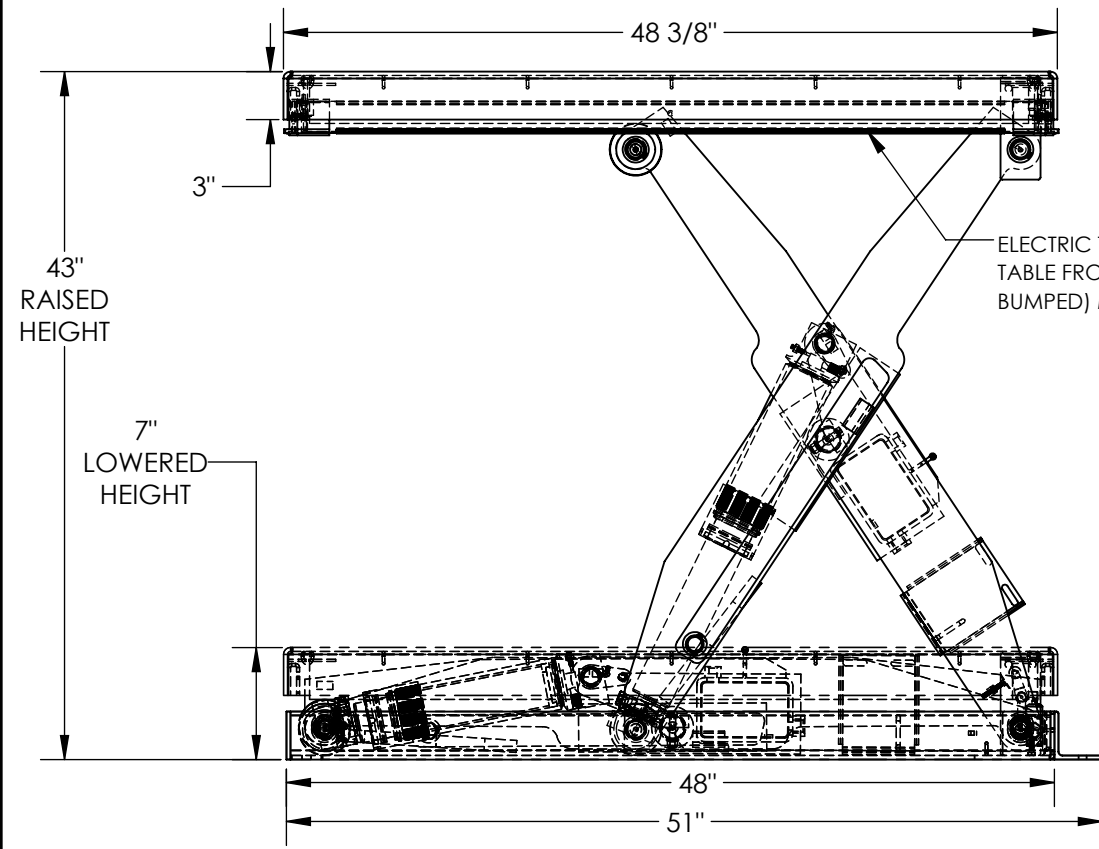

DIMENSION TOLERANCE ± 1/4"

## STANDARD FEATURES

MODEL NUMBER IS EHLT-2448-2-43-PSS  
 PLATFORM WIDTH IS 24 3/8"  
 PLATFORM LENGTH IS 48 3/8"  
 OVERALL LENGTH IS 51"  
 PLATFORM RAISED HEIGHT IS 43"  
 PLATFORM LOWERED HEIGHT IS 7"  
 TABLE CAPACITY (EVENLY DISTRIBUTED)  
 LOAD IS 2,000 LBS  
 CONTROLS HAND PENDANT ON 8' CORD  
 SAFETY MAINTENANCE PROPS, DISPLACEMENT  
 STYLE CYLINDERS INSTALLED ROD DOWN  
 EMERGENCY SAFETY STOP HYDRAULIC FUSES  
 IN ALL CYLINDER. UNITS HAVE 2' TEST LEAD  
 AND PIG TAIL  
 FRAME AND DECK - MILL FINISH 304 STAINLESS STEEL  
 GREASABLE PINS AND ROLLERS - 17-4 STAINLESS STEEL  
 SCISSOR LEGSET - CARBON STEEL WITH  
 TOUGH BAKED IN POWDER COATED WHITE FINISH

## PLEASE CIRCLE SPECIFICATIONS:

POWER	AC	<del>DC (12V)</del>	AIR/OIL
MOTOR VOLTAGE	115	<del>208</del>	<del>230</del> 460
DEDICATED CIRCUIT REQUIRED 60Hz			
MOTOR PHASE	<del>SINGLE</del>	THREE	
CONTROL	HAND	<del>FOOT</del>	

FOR INTERNAL USE ONLY PROJECT SIGN OFF	
SALES	
ENG.	
FAB.	
POWER	

DECK TOLERANCE ± 1/2"  
 TABLE HEIGHT TOLERANCE ± 1/2"  
 DECK FLATNESS ± 1/4"

## SPECIAL FEATURES NONE

**A P P R O V A L**

I, THE UNDERSIGNED, AGREE THAT THE PRODUCT AS REPRESENTED SATISFIES DESIGN AND DIMENSION REQUIREMENTS. I ALSO ACKNOWLEDGE MY DUTY TO CONFIRM PRODUCT AND INSTALLATION COMPLIANCE WITH ALL APPLICABLE FEDERAL, STATE AND LOCAL REGULATIONS AND STANDARDS.  
**ANY MODIFIED UNITS ARE NON-RETURNABLE**  
 As drawn       As marked

Signed: \_\_\_\_\_ Date: \_\_\_\_\_  
 Printed Name: \_\_\_\_\_  
**LEAD TIME WILL START UPON RECEIPT OF SIGNED APPROVAL DRAWING**

DISTRIBUTOR'S NAME:		P.O.#
VESTIL MANUFACTURING		X
DRAWN BY: BCN		W.O.#
DATE: 8/30/2017		X
REFERENCE: X	SCALE: 1:12	SALES: X
QUOTED LEAD TIME: X	QUOTE # X	FILE NAME:
		24-007-015-001

# ELECTRIC HYDRAULIC SCISSOR LIFT TABLE, PARTIAL STAINLESS STEEL - EHLT-2448-3-43-PSS

APPROX WEIGHT: 609.78 lbs.  
 DOES NOT INCLUDE WEIGHT OF POWER OR PACKAGING!!!

\*\*\* ANY ADDITIONS, DELETIONS, OR OMISSIONS MUST BE CORRECTED ON THIS DRAWING AS THIS DRAWING WILL BE CONSIDERED ALL INCLUSIVE \*\*\*  
 ALL GRAPHICS PROVIDED ARE FOR REFERENCE ONLY. IF CERTAIN DIMENSIONS ARE CRITICAL PLEASE VERIFY THOSE DIMENSIONS WITH YOUR SALESPERSON

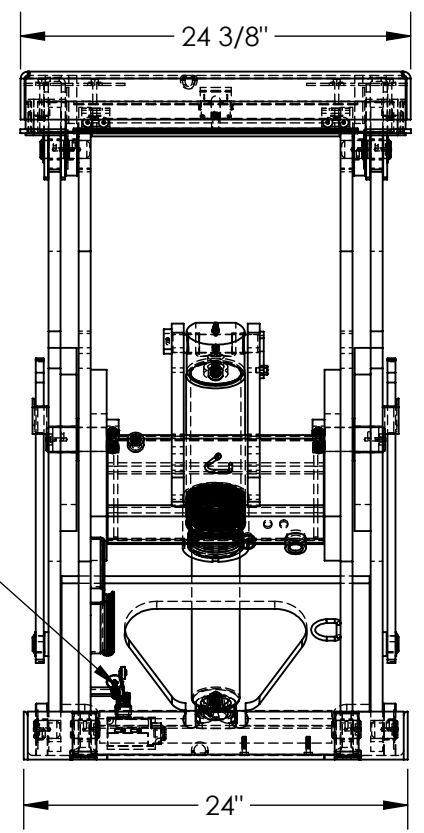
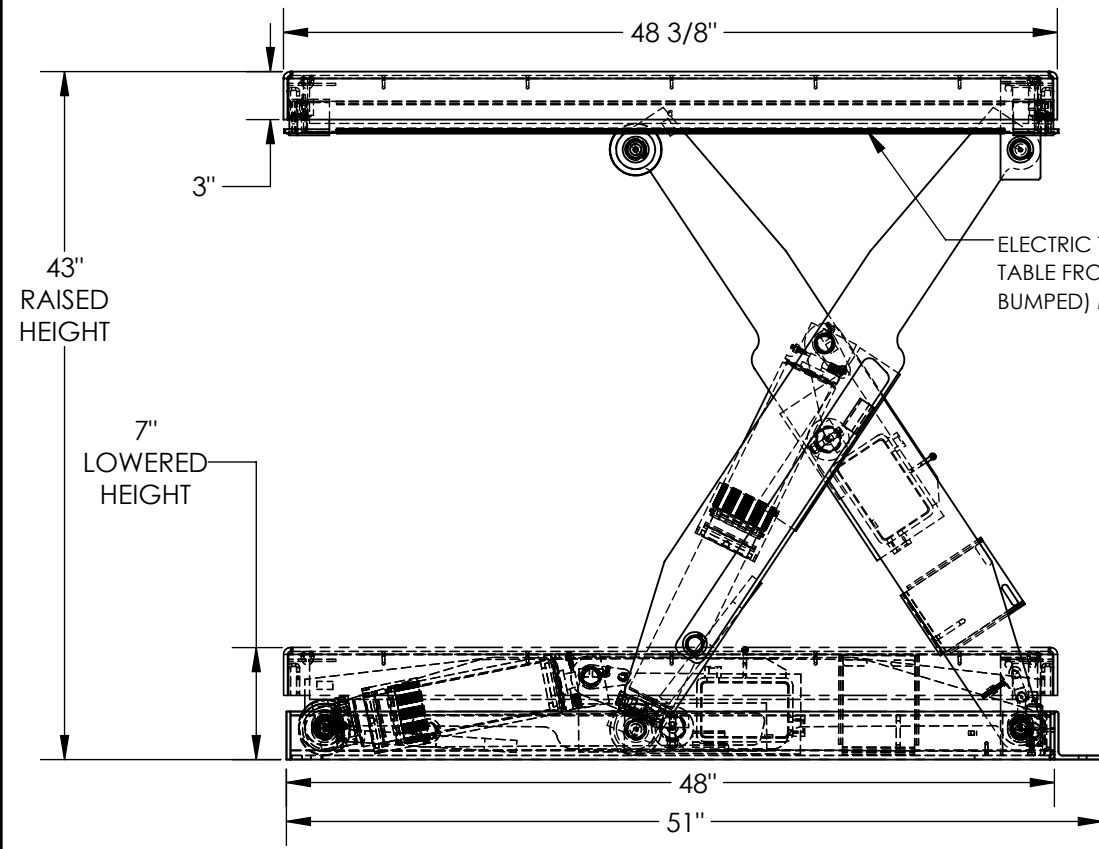

DIMENSION TOLERANCE ± 1/4"

## STANDARD FEATURES

- MODEL NUMBER IS EHLT-2448-3-43-PSS
- PLATFORM WIDTH IS 24 3/8"
- PLATFORM LENGTH IS 48 3/8"
- OVERALL LENGTH IS 51"
- PLATFORM RAISED HEIGHT IS 43"
- PLATFORM LOWERED HEIGHT IS 7"
- TABLE CAPACITY (EVENLY DISTRIBUTED) LOAD IS 3,000 LBS
- CONTROLS HAND PENDANT ON 8' CORD
- SAFETY MAINTENANCE PROPS, DISPLACEMENT STYLE CYLINDERS INSTALLED ROD DOWN EMERGENCY SAFETY STOP HYDRAULIC FUSES IN ALL CYLINDER. UNITS HAVE 2' TEST LEAD AND PIG TAIL
- FRAME AND DECK - MILL FINISH 304 STAINLESS STEEL
- GREASABLE PINS AND ROLLERS - 17-4 STAINLESS STEEL
- SCISSOR LEGSET - CARBON STEEL WITH TOUGH BAKED IN POWDER COATED WHITE FINISH

## PLEASE CIRCLE SPECIFICATIONS:

POWER	AC	<del>DC (12V)</del>	<del>AIR/OIL</del>
MOTOR VOLTAGE	<del>115</del>	<del>208</del>	<del>230</del> 460
DEDICATED CIRCUIT REQUIRED 60Hz			
MOTOR PHASE	<del>SINGLE</del>	THREE	
CONTROL	HAND	<del>FOOT</del>	

FOR INTERNAL USE ONLY PROJECT SIGN OFF	
SALES	
ENG.	
FAB.	
POWER	

DECK TOLERANCE ± 1/2"  
 TABLE HEIGHT TOLERANCE ± 1/2"  
 DECK FLATNESS ± 1/4"

## SPECIAL FEATURES NONE

**APPROVAL**

I, THE UNDERSIGNED, AGREE THAT THE PRODUCT AS REPRESENTED SATISFIES DESIGN AND DIMENSION REQUIREMENTS. I ALSO ACKNOWLEDGE MY DUTY TO CONFIRM PRODUCT AND INSTALLATION COMPLIANCE WITH ALL APPLICABLE FEDERAL, STATE AND LOCAL REGULATIONS AND STANDARDS.  
**ANY MODIFIED UNITS ARE NON-RETURNABLE**  
 As drawn       As marked

Signed: \_\_\_\_\_ Date: \_\_\_\_\_  
 Printed Name: \_\_\_\_\_  
**LEAD TIME WILL START UPON RECEIPT OF SIGNED APPROVAL DRAWING**

DISTRIBUTOR'S NAME:		P.O.#
VESTIL MANUFACTURING		X
DRAWN BY: BCN		W.O.#
DATE: 8/30/2017		X
REFERENCE: X	SCALE: 1:12	SALES: X
QUOTED LEAD TIME: X	QUOTE # X	FILE NAME:
		24-007-025-001

# ELECTRIC HYDRAULIC SCISSOR LIFT TABLE, PARTIAL STAINLESS STEEL - EHLT-2448-4-43-PSS

APPROX WEIGHT: 633.04 lbs.  
 DOES NOT INCLUDE WEIGHT OF POWER OR PACKAGING!!!

\*\*\* ANY ADDITIONS, DELETIONS, OR OMISSIONS MUST BE CORRECTED ON THIS DRAWING AS THIS DRAWING WILL BE CONSIDERED ALL INCLUSIVE \*\*\*  
 ALL GRAPHICS PROVIDED ARE FOR REFERENCE ONLY. IF CERTAIN DIMENSIONS ARE CRITICAL PLEASE VERIFY THOSE DIMENSIONS WITH YOUR SALESPERSON

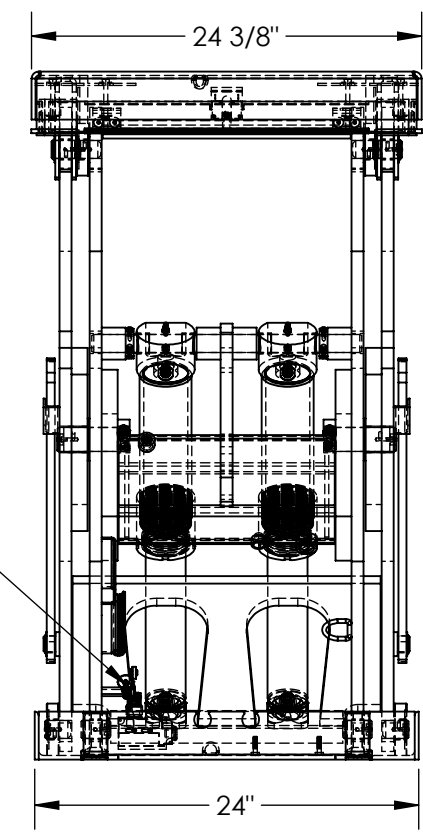
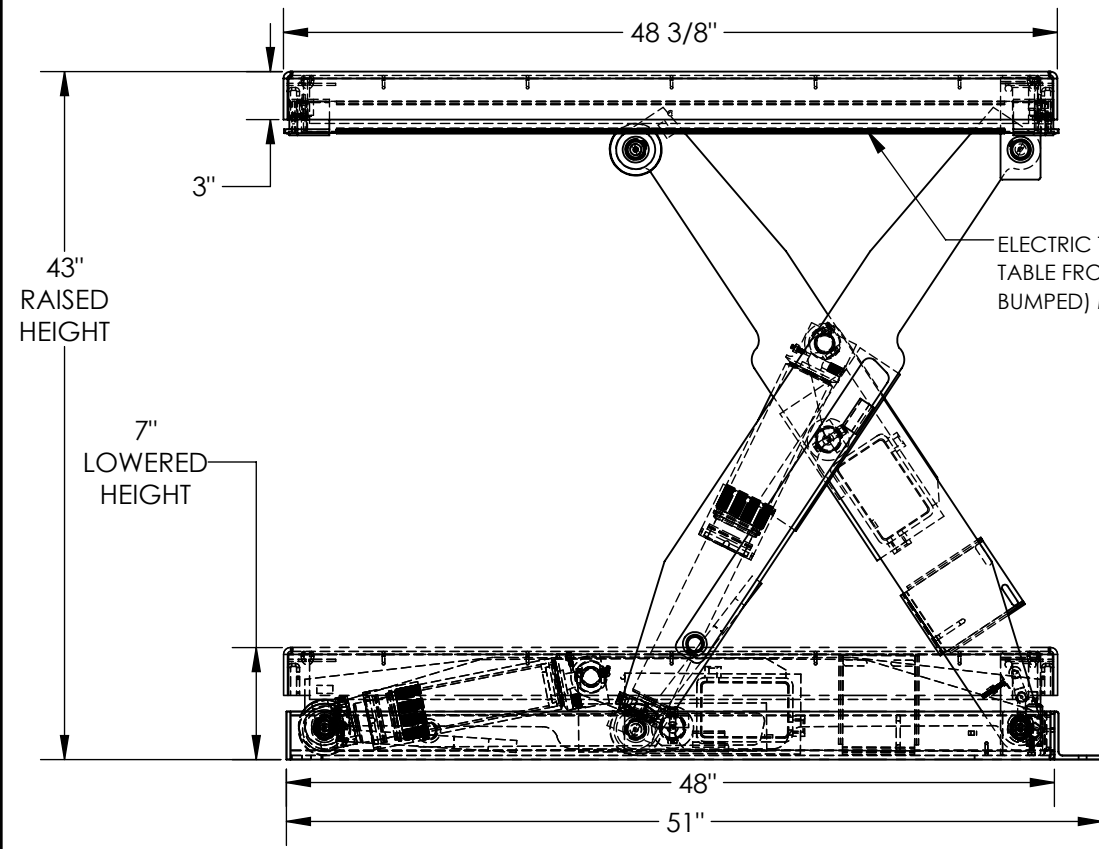

DIMENSION TOLERANCE ± 1/4"

## STANDARD FEATURES

MODEL NUMBER IS EHLT-2448-4-43-PSS  
 PLATFORM WIDTH IS 24 3/8"  
 PLATFORM LENGTH IS 48 3/8"  
 OVERALL LENGTH IS 51"  
 PLATFORM RAISED HEIGHT IS 43"  
 PLATFORM LOWERED HEIGHT IS 7"  
 TABLE CAPACITY (EVENLY DISTRIBUTED)  
 LOAD IS 4,000 LBS  
 CONTROLS HAND PENDANT ON 8' CORD  
 SAFETY MAINTENANCE PROPS, DISPLACEMENT  
 STYLE CYLINDERS INSTALLED ROD DOWN  
 EMERGENCY SAFETY STOP HYDRAULIC FUSES  
 IN ALL CYLINDER. UNITS HAVE 2' TEST LEAD  
 AND PIG TAIL  
 FRAME AND DECK - MILL FINISH 304 STAINLESS STEEL  
 GREASABLE PINS AND ROLLERS - 17-4 STAINLESS STEEL  
 SCISSOR LEGSET - CARBON STEEL WITH  
 TOUGH BAKED IN POWDER COATED WHITE FINISH

## PLEASE CIRCLE SPECIFICATIONS:

POWER	AC	<del>DC (12V)</del>	AIR/OIL
MOTOR VOLTAGE	115	<del>208</del>	<del>230</del> 460
DEDICATED CIRCUIT REQUIRED 60Hz			
MOTOR PHASE	<del>SINGLE</del>	THREE	
CONTROL	HAND	<del>FOOT</del>	

FOR INTERNAL USE ONLY PROJECT SIGN OFF	
SALES	
ENG.	
FAB.	
POWER	

DECK TOLERANCE ± 1/2"  
 TABLE HEIGHT TOLERANCE ± 1/2"  
 DECK FLATNESS ± 1/4"

## SPECIAL FEATURES NONE

**APPROVAL**

I, THE UNDERSIGNED, AGREE THAT THE PRODUCT AS REPRESENTED SATISFIES DESIGN AND DIMENSION REQUIREMENTS. I ALSO ACKNOWLEDGE MY DUTY TO CONFIRM PRODUCT AND INSTALLATION COMPLIANCE WITH ALL APPLICABLE FEDERAL, STATE AND LOCAL REGULATIONS AND STANDARDS.  
**ANY MODIFIED UNITS ARE NON-RETURNABLE**  
 As drawn       As marked

Signed: \_\_\_\_\_ Date: \_\_\_\_\_  
 Printed Name: \_\_\_\_\_  
**LEAD TIME WILL START UPON RECEIPT OF SIGNED APPROVAL DRAWING**

DISTRIBUTOR'S NAME:		P.O.#
VESTIL MANUFACTURING		X
DRAWN BY: BCN		W.O.#
DATE: 8/30/2017		X
REFERENCE: X	SCALE: 1:12	SALES: X
QUOTED LEAD TIME: X	QUOTE #	FILE NAME:
	X	24-007-095-001

**ELECTRIC HYDRAULIC SCISSOR LIFT TABLE, PARTIAL STAINLESS STEEL - EHLT-4848-1-43-PSS** APPROX WEIGHT: 718.90 lbs. DOES NOT INCLUDE WEIGHT OF POWER OR PACKAGING!!!

\*\*\* ANY ADDITIONS, DELETIONS, OR OMISSIONS MUST BE CORRECTED ON THIS DRAWING AS THIS DRAWING WILL BE CONSIDERED ALL INCLUSIVE \*\*\* ALL GRAPHICS PROVIDED ARE FOR REFERENCE ONLY. IF CERTAIN DIMENSIONS ARE CRITICAL PLEASE VERIFY THOSE DIMENSIONS WITH YOUR SALESPERSON

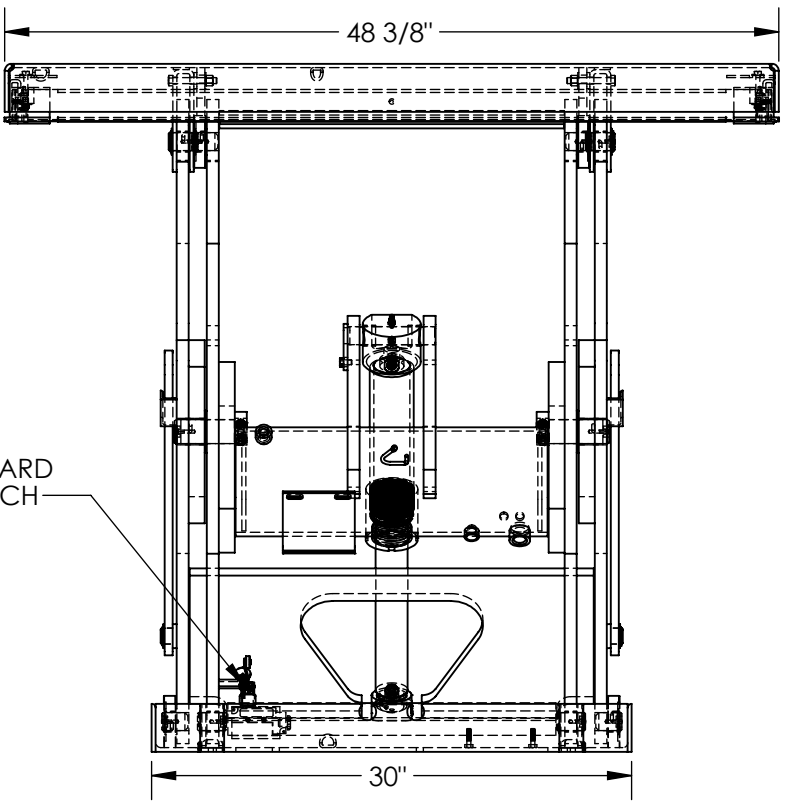
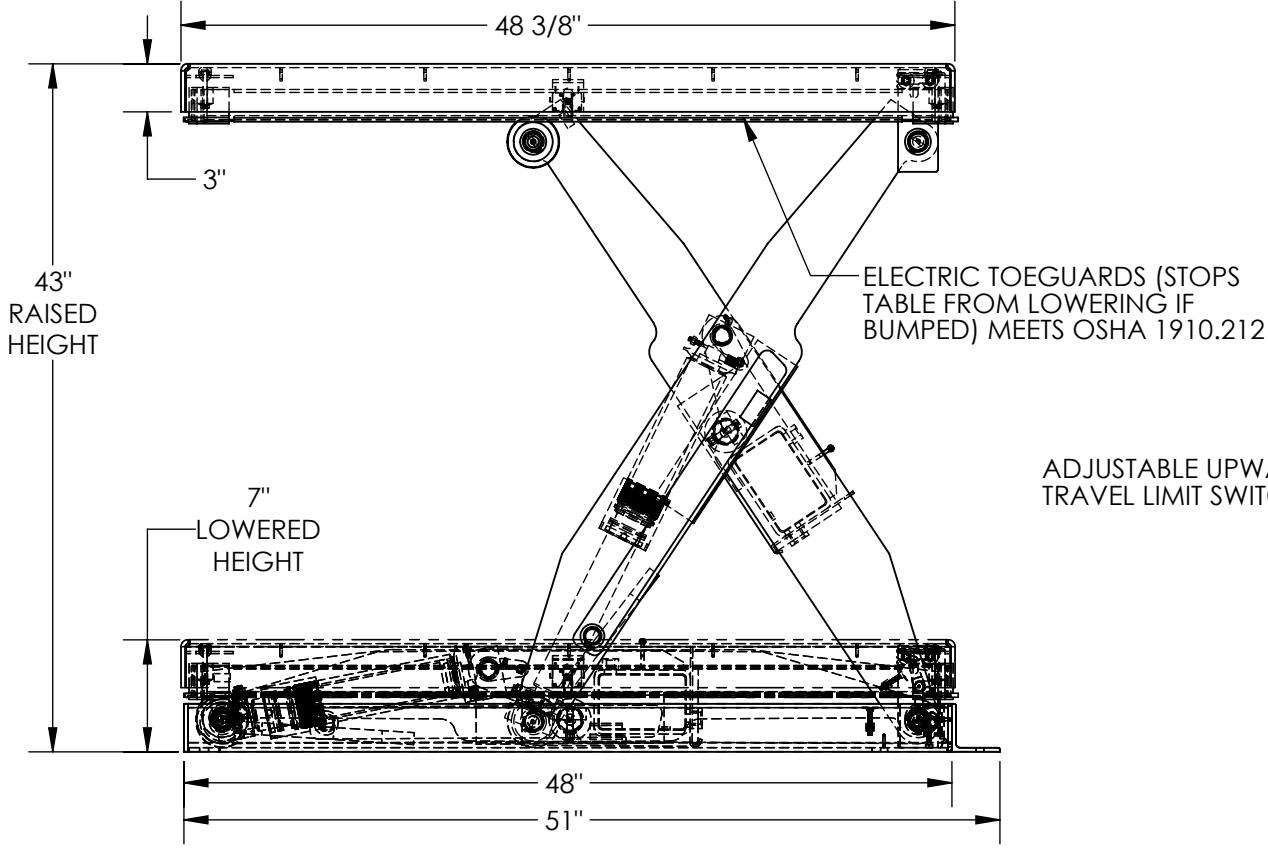

**STANDARD FEATURES**

MODEL NUMBER IS EHLT-4848-1-43-PSS  
 PLATFORM WIDTH IS 48 3/8"  
 PLATFORM LENGTH IS 48 3/8"  
 OVERALL LENGTH IS 51"  
 PLATFORM RAISED HEIGHT IS 43"  
 PLATFORM LOWERED HEIGHT IS 7"  
 TABLE CAPACITY (EVENLY DISTRIBUTED) LOAD IS 1,000 LBS  
 CONTROLS HAND PENDANT ON 8' CORD  
 SAFETY MAINTENANCE PROPS, DISPLACEMENT STYLE CYLINDERS INSTALLED ROD DOWN EMERGENCY SAFETY STOP HYDRAULIC FUSES IN ALL CYLINDER. UNITS HAVE 2' TEST LEAD AND PIG TAIL  
 FRAME AND DECK - MILL FINISH 304 STAINLESS STEEL  
 GREASABLE PINS AND ROLLERS - 17-4 STAINLESS STEEL  
 SCISSOR LEGSET - CARBON STEEL WITH TOUGH BAKED IN POWDER COATED WHITE FINISH

**SPECIAL FEATURES**  
 NONE

DECK TOLERANCE ± 1/2"  
 TABLE HEIGHT TOLERANCE ± 1/2"  
 DECK FLATNESS ± 1/4"

**PLEASE CIRCLE SPECIFICATIONS:**

POWER	AC	<del>DC (12V)</del>	AIR/OIL
MOTOR VOLTAGE	115	208	230 460
DEDICATED CIRCUIT REQUIRED 60Hz			
MOTOR PHASE	<del>SINGLE</del>	THREE	
CONTROL	HAND	<del>FOOT</del>	

FOR INTERNAL USE ONLY PROJECT SIGN OFF	
SALES	
ENG.	
FAB.	
POWER	

DIMENSION TOLERANCE ± 1/4"

**APPROVAL**

I, THE UNDERSIGNED, AGREE THAT THE PRODUCT AS REPRESENTED SATISFIES DESIGN AND DIMENSION REQUIREMENTS. I ALSO ACKNOWLEDGE MY DUTY TO CONFIRM PRODUCT AND INSTALLATION COMPLIANCE WITH ALL APPLICABLE FEDERAL, STATE AND LOCAL REGULATIONS AND STANDARDS.

**ANY MODIFIED UNITS ARE NON-RETURNABLE**

[ ] As drawn [ ] As marked

Signed: \_\_\_\_\_ Date: \_\_\_\_\_

Printed Name: \_\_\_\_\_

LEAD TIME WILL START UPON RECEIPT OF SIGNED APPROVAL DRAWING

DISTRIBUTOR'S NAME:		P.O.#
VESTIL MANUFACTURING		X
DRAWN BY: BCN	DATE: 8/30/2017	W.O.#
REFERENCE: X	SCALE: 1:12	X
QUOTED LEAD TIME: X	QUOTE #	SALES: X
	X	FILE NAME:
		24-007-035-001

# ELECTRIC HYDRAULIC SCISSOR LIFT TABLE, PARTIAL STAINLESS STEEL - EHLT-4848-2-43-PSS

APPROX WEIGHT: 726.60 lbs.  
DOES NOT INCLUDE WEIGHT OF POWER OR PACKAGING!!!

\*\*\* ANY ADDITIONS, DELETIONS, OR OMISSIONS MUST BE CORRECTED ON THIS DRAWING AS THIS DRAWING WILL BE CONSIDERED ALL INCLUSIVE \*\*\*  
ALL GRAPHICS PROVIDED ARE FOR REFERENCE ONLY. IF CERTAIN DIMENSIONS ARE CRITICAL PLEASE VERIFY THOSE DIMENSIONS WITH YOUR SALESPERSON

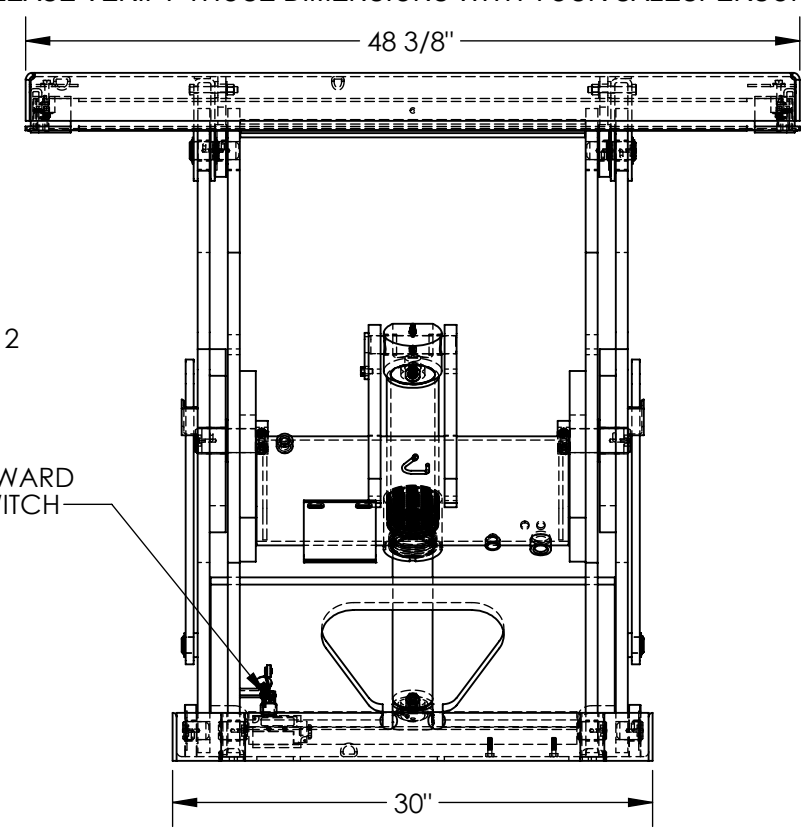
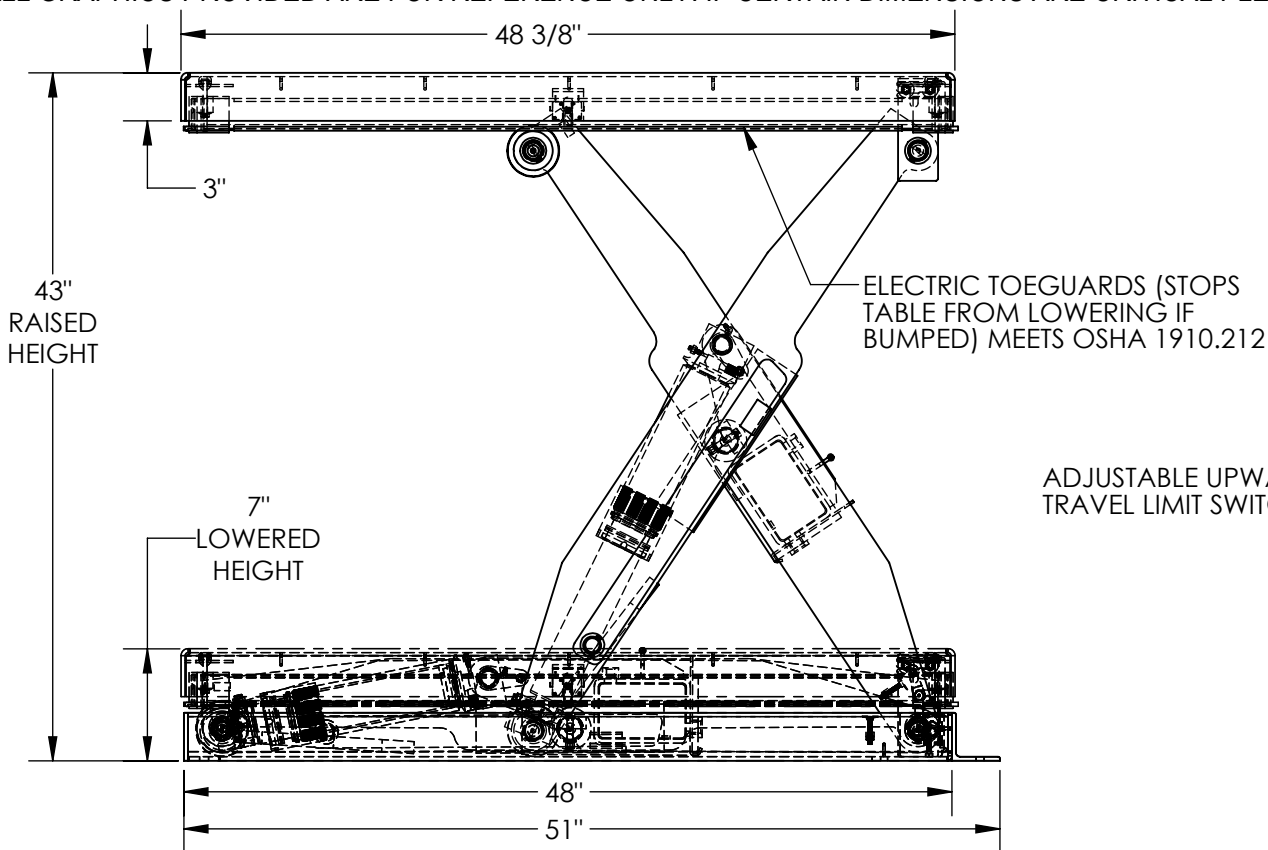

DIMENSION TOLERANCE ± 1/4"

## STANDARD FEATURES

- MODEL NUMBER IS EHLT-4848-2-43-PSS
- PLATFORM WIDTH IS 48 3/8"
- PLATFORM LENGTH IS 48 3/8"
- OVERALL LENGTH IS 51"
- PLATFORM RAISED HEIGHT IS 43"
- PLATFORM LOWERED HEIGHT IS 7"
- TABLE CAPACITY (EVENLY DISTRIBUTED) LOAD IS 2,000 LBS
- CONTROLS HAND PENDANT ON 8' CORD
- SAFETY MAINTENANCE PROPS, DISPLACEMENT STYLE CYLINDERS INSTALLED ROD DOWN EMERGENCY SAFETY STOP HYDRAULIC FUSES IN ALL CYLINDER. UNITS HAVE 2' TEST LEAD AND PIG TAIL
- FRAME AND DECK - MILL FINISH 304 STAINLESS STEEL
- GREASABLE PINS AND ROLLERS - 17-4 STAINLESS STEEL
- SCISSOR LEGSET - CARBON STEEL WITH TOUGH BAKED IN POWDER COATED WHITE FINISH

## PLEASE CIRCLE SPECIFICATIONS:

POWER	AC	<del>DC (12V)</del>	<del>AIR/OIL</del>
MOTOR VOLTAGE	<u>115</u>	<del>208</del>	<del>230</del> <del>460</del>
DEDICATED CIRCUIT REQUIRED 60Hz			
MOTOR PHASE	<del>SINGLE</del>	<u>THREE</u>	
CONTROL	<u>HAND</u>	<del>FOOT</del>	

FOR INTERNAL USE ONLY PROJECT SIGN OFF	
SALES	
ENG.	
FAB.	
POWER	

DECK TOLERANCE ± 1/2"  
TABLE HEIGHT TOLERANCE ± 1/2"  
DECK FLATNESS ± 1/4"

## SPECIAL FEATURES NONE

**APPROVAL**

I, THE UNDERSIGNED, AGREE THAT THE PRODUCT AS REPRESENTED SATISFIES DESIGN AND DIMENSION REQUIREMENTS. I ALSO ACKNOWLEDGE MY DUTY TO CONFIRM PRODUCT AND INSTALLATION COMPLIANCE WITH ALL APPLICABLE FEDERAL, STATE AND LOCAL REGULATIONS AND STANDARDS.

**ANY MODIFIED UNITS ARE NON-RETURNABLE**

[ ] As drawn [ ] As marked

Signed: \_\_\_\_\_ Date: \_\_\_\_\_

Printed Name: \_\_\_\_\_

LEAD TIME WILL START UPON RECEIPT OF SIGNED APPROVAL DRAWING

DISTRIBUTOR'S NAME:		P.O.#
VESTIL MANUFACTURING		X
DRAWN BY: BCN		W.O.#
DATE: 8/30/2017		X
REFERENCE: X	SCALE: 1:12	SALES: X
QUOTED LEAD TIME: X	QUOTE # X	FILE NAME:
		24-007-045-001

# ELECTRIC HYDRAULIC SCISSOR LIFT TABLE, PARTIAL STAINLESS STEEL - EHLT-4848-3-43-PSS

APPROX WEIGHT: 736.82 lbs.  
DOES NOT INCLUDE WEIGHT OF POWER OR PACKAGING!!!

\*\*\* ANY ADDITIONS, DELETIONS, OR OMISSIONS MUST BE CORRECTED ON THIS DRAWING AS THIS DRAWING WILL BE CONSIDERED ALL INCLUSIVE \*\*\*  
ALL GRAPHICS PROVIDED ARE FOR REFERENCE ONLY. IF CERTAIN DIMENSIONS ARE CRITICAL PLEASE VERIFY THOSE DIMENSIONS WITH YOUR SALESPERSON

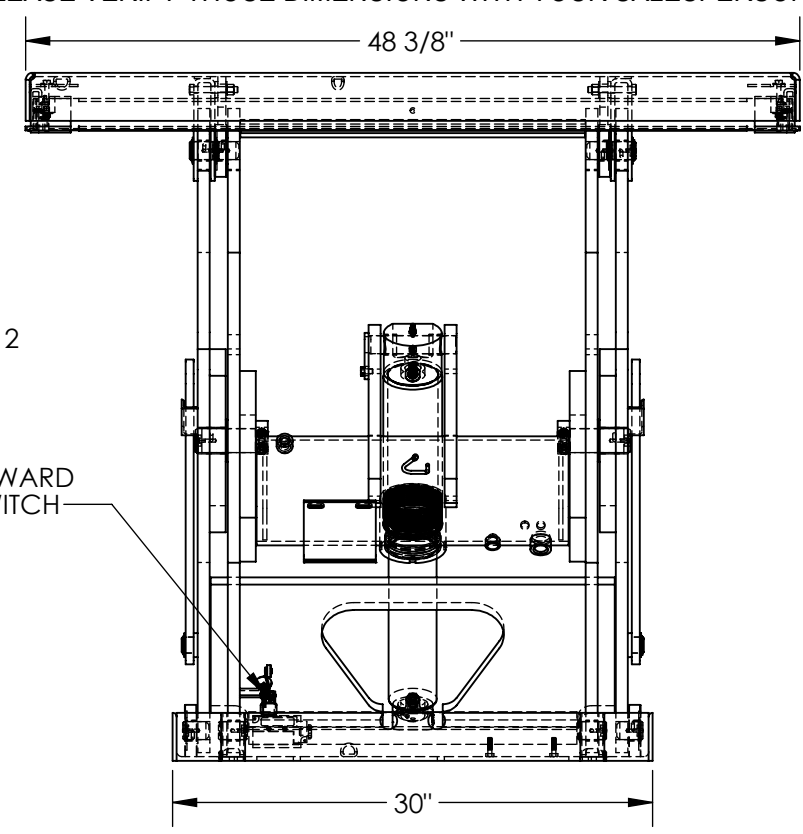
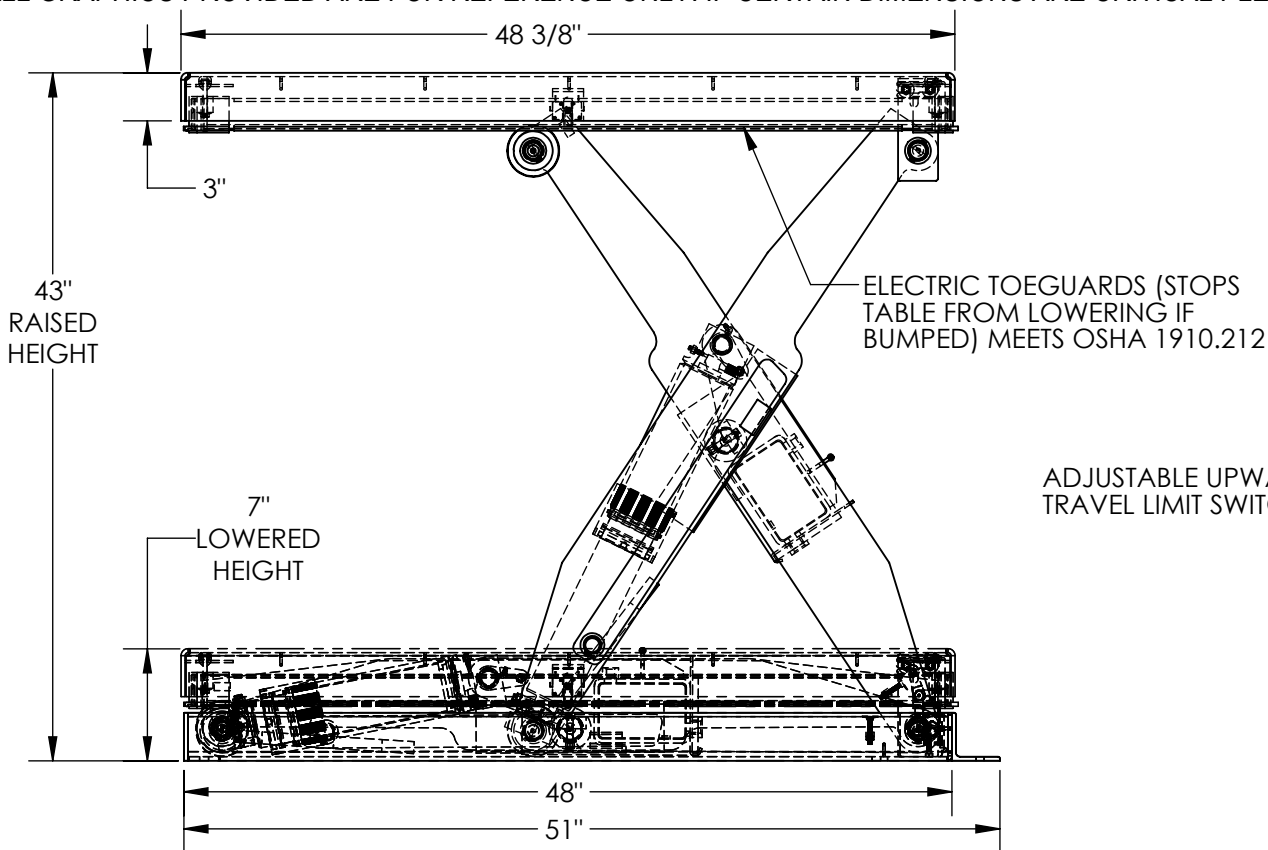

DIMENSION TOLERANCE ± 1/4"

## STANDARD FEATURES

MODEL NUMBER IS EHLT-4848-3-43-PSS  
 PLATFORM WIDTH IS 48 3/8"  
 PLATFORM LENGTH IS 48 3/8"  
 OVERALL LENGTH IS 51"  
 PLATFORM RAISED HEIGHT IS 43"  
 PLATFORM LOWERED HEIGHT IS 7"  
 TABLE CAPACITY (EVENLY DISTRIBUTED)  
 LOAD IS 3,000 LBS  
 CONTROLS HAND PENDANT ON 8' CORD  
 SAFETY MAINTENANCE PROPS, DISPLACEMENT  
 STYLE CYLINDERS INSTALLED ROD DOWN  
 EMERGENCY SAFETY STOP HYDRAULIC FUSES  
 IN ALL CYLINDER. UNITS HAVE 2' TEST LEAD  
 AND PIG TAIL  
 FRAME AND DECK - MILL FINISH 304 STAINLESS STEEL  
 GREASABLE PINS AND ROLLERS - 17-4 STAINLESS STEEL  
 SCISSOR LEGSET - CARBON STEEL WITH  
 TOUGH BAKED IN POWDER COATED WHITE FINISH

## PLEASE CIRCLE SPECIFICATIONS:

POWER	AC	<del>DC (12V)</del>	AIR/OIL
MOTOR VOLTAGE	115	208	230 460
DEDICATED CIRCUIT REQUIRED 60Hz			
MOTOR PHASE	<del>SINGLE</del>	THREE	
CONTROL	HAND	<del>FOOT</del>	

FOR INTERNAL USE ONLY PROJECT SIGN OFF	
SALES	
ENG.	
FAB.	
POWER	

DECK TOLERANCE ± 1/2"  
 TABLE HEIGHT TOLERANCE ± 1/2"  
 DECK FLATNESS ± 1/4"

## SPECIAL FEATURES NONE

**APPROVAL**

I, THE UNDERSIGNED, AGREE THAT THE PRODUCT AS REPRESENTED SATISFIES DESIGN AND DIMENSION REQUIREMENTS. I ALSO ACKNOWLEDGE MY DUTY TO CONFIRM PRODUCT AND INSTALLATION COMPLIANCE WITH ALL APPLICABLE FEDERAL, STATE AND LOCAL REGULATIONS AND STANDARDS.  
**ANY MODIFIED UNITS ARE NON-RETURNABLE**  
 As drawn       As marked

Signed: \_\_\_\_\_ Date: \_\_\_\_\_  
 Printed Name: \_\_\_\_\_

**LEAD TIME WILL START UPON RECEIPT OF SIGNED APPROVAL DRAWING**

DISTRIBUTOR'S NAME:		P.O.#
VESTIL MANUFACTURING		X
DRAWN BY: BCN		W.O.#
DATE: 8/30/2017		X
REFERENCE: X	SCALE: 1:12	SALES: X
QUOTED LEAD TIME: X	QUOTE #	FILE NAME:
	X	24-007-055-001

# ELECTRIC HYDRAULIC SCISSOR LIFT TABLE, PARTIAL STAINLESS STEEL - EHLT-4848-4-43-PSS

APPROX WEIGHT: 764.74 lbs.  
 DOES NOT INCLUDE WEIGHT OF POWER OR PACKAGING!!!

\*\*\* ANY ADDITIONS, DELETIONS, OR OMISSIONS MUST BE CORRECTED ON THIS DRAWING AS THIS DRAWING WILL BE CONSIDERED ALL INCLUSIVE \*\*\*  
 ALL GRAPHICS PROVIDED ARE FOR REFERENCE ONLY. IF CERTAIN DIMENSIONS ARE CRITICAL PLEASE VERIFY THOSE DIMENSIONS WITH YOUR SALESPERSON

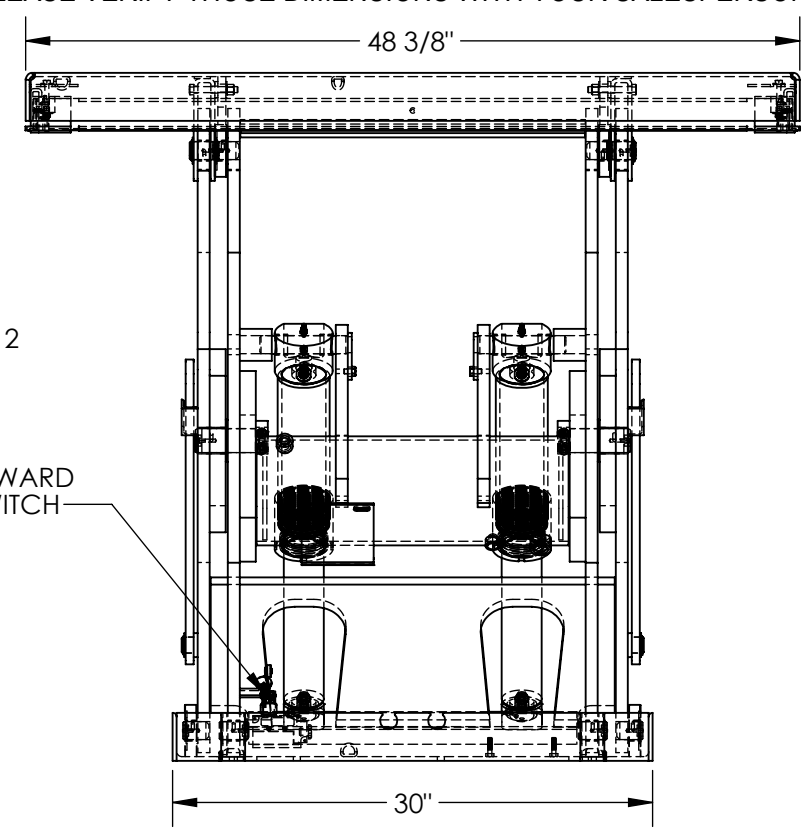
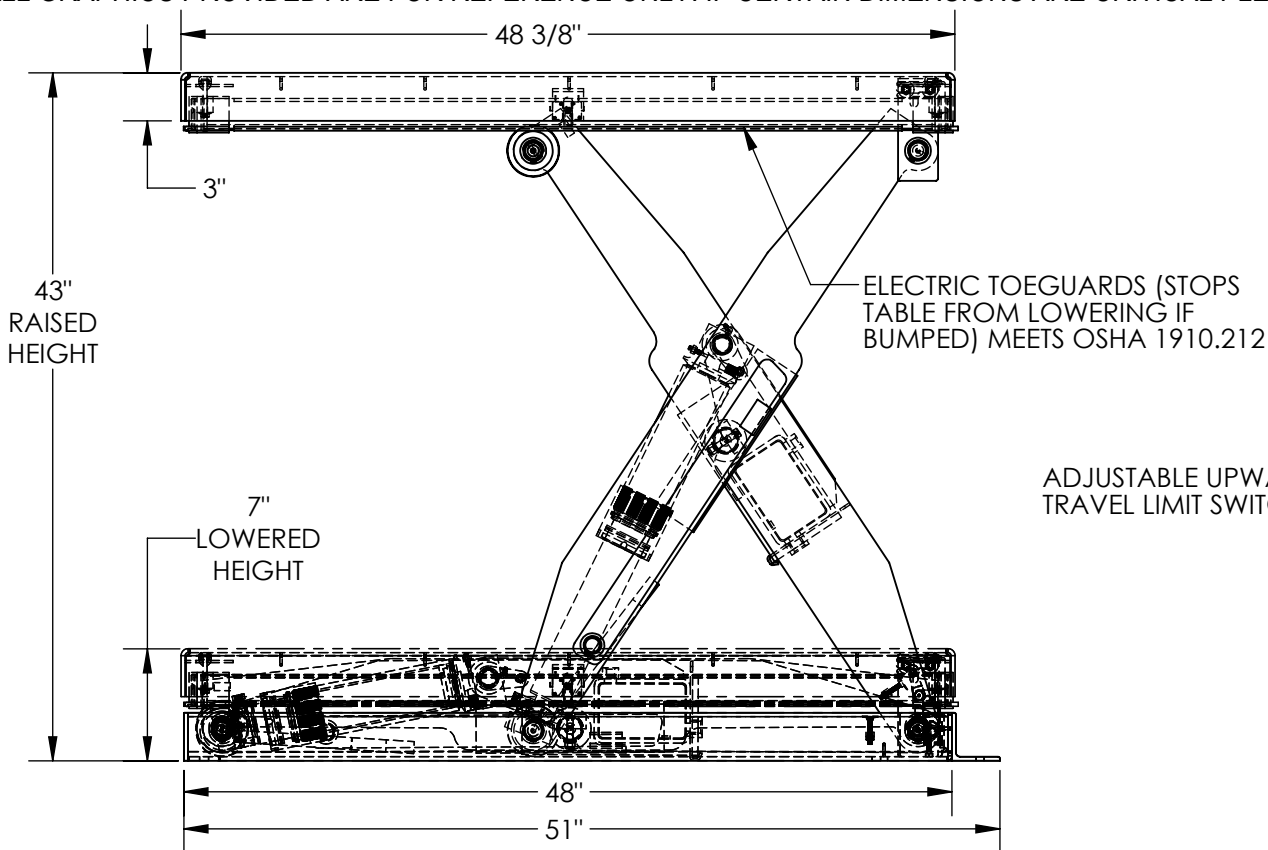

DIMENSION TOLERANCE ± 1/4"

## STANDARD FEATURES

MODEL NUMBER IS EHLT-4848-4-43-PSS  
 PLATFORM WIDTH IS 48 3/8"  
 PLATFORM LENGTH IS 48 3/8"  
 OVERALL LENGTH IS 51"  
 PLATFORM RAISED HEIGHT IS 43"  
 PLATFORM LOWERED HEIGHT IS 7"  
 TABLE CAPACITY (EVENLY DISTRIBUTED)  
 LOAD IS 4,000 LBS  
 CONTROLS HAND PENDANT ON 8' CORD  
 SAFETY MAINTENANCE PROPS, DISPLACEMENT  
 STYLE CYLINDERS INSTALLED ROD DOWN  
 EMERGENCY SAFETY STOP HYDRAULIC FUSES  
 IN ALL CYLINDER. UNITS HAVE 2' TEST LEAD  
 AND PIG TAIL  
 FRAME AND DECK - MILL FINISH 304 STAINLESS STEEL  
 GREASABLE PINS AND ROLLERS - 17-4 STAINLESS STEEL  
 SCISSOR LEGSET - CARBON STEEL WITH  
 TOUGH BAKED IN POWDER COATED WHITE FINISH

## PLEASE CIRCLE SPECIFICATIONS:

POWER	AC	<del>DC (12V)</del>	<del>AIR/OIL</del>
MOTOR VOLTAGE	<del>115</del>	<del>208</del>	<del>230</del> 460
DEDICATED CIRCUIT REQUIRED 60Hz			
MOTOR PHASE	<del>SINGLE</del>	THREE	
CONTROL	HAND	<del>FOOT</del>	

FOR INTERNAL USE ONLY PROJECT SIGN OFF	
SALES	
ENG.	
FAB.	
POWER	

DECK TOLERANCE ± 1/2"  
 TABLE HEIGHT TOLERANCE ± 1/2"  
 DECK FLATNESS ± 1/4"

## SPECIAL FEATURES NONE

**APPROVAL**

I, THE UNDERSIGNED, AGREE THAT THE PRODUCT AS REPRESENTED SATISFIES DESIGN AND DIMENSION REQUIREMENTS. I ALSO ACKNOWLEDGE MY DUTY TO CONFIRM PRODUCT AND INSTALLATION COMPLIANCE WITH ALL APPLICABLE FEDERAL, STATE AND LOCAL REGULATIONS AND STANDARDS.  
**ANY MODIFIED UNITS ARE NON-RETURNABLE**  
 As drawn       As marked

Signed: \_\_\_\_\_ Date: \_\_\_\_\_  
 Printed Name: \_\_\_\_\_  
**LEAD TIME WILL START UPON RECEIPT OF SIGNED APPROVAL DRAWING**

DISTRIBUTOR'S NAME:		P.O.#
VESTIL MANUFACTURING		X
DRAWN BY: BCN		W.O.#
DATE: 8/30/2017		X
REFERENCE: X	SCALE: 1:12	SALES: X
QUOTED LEAD TIME: X	QUOTE #	FILE NAME:
	X	24-007-115-001