

Model 186

Adjusts to Various Diameter Drums



Handles a Wide Range of Drum Diameters

- Unique pads conform to drum for a secure grip
- Transport loaded drum by crane, hoist or chain block
- Allows fast dispensing of your drum
- High level controlled pouring

Morse Adjusto-Karrier provides a convenient means of pouring into high chutes, hoppers, vessels, etc. It is adjustable to fit a specified range of diameters for handling fiber or steel drums (with or without ribs) weighing up to 500 Lb. (227 kg). A hand operated pull chain permits gear driven tilt control for pouring above a person's reach. The 30:1 gears are equipped with safety covers.

To attach your Adjusto-Karrier to a drum, simply back-off the adjusting screws using the removable crank furnished. The center rod of the three rods on each side is a threaded adjusting screw. The others are guide rods (shown in dimensions diagram). Hoist the unit up over the drum and lower it to a point where the gripping pads are adjacent to the center of the load. Turn the adjusting screws to tighten the grip pads to hold the drum approximately centered in the holder frame. Turning the adjusting crank allows the operator to "feel" the resistance of the pressure being applied, so denting or crushing the container can be prevented.

The unique grip pads, made of a nylon core with nitrile blend cover, conform to the drum curvature to grip securely.

When successive drums are the same diameter, gripping and releasing involves just one adjusting screw. The other one need not be readjusted until a different diameter is encountered. Then it may be readjusted to center the new drum.

- Adjusts for 15" to 23" (38.1 to 58.4 cm) diameter steel or fiber drum
- NOT for use with plastic drum

Dimensions

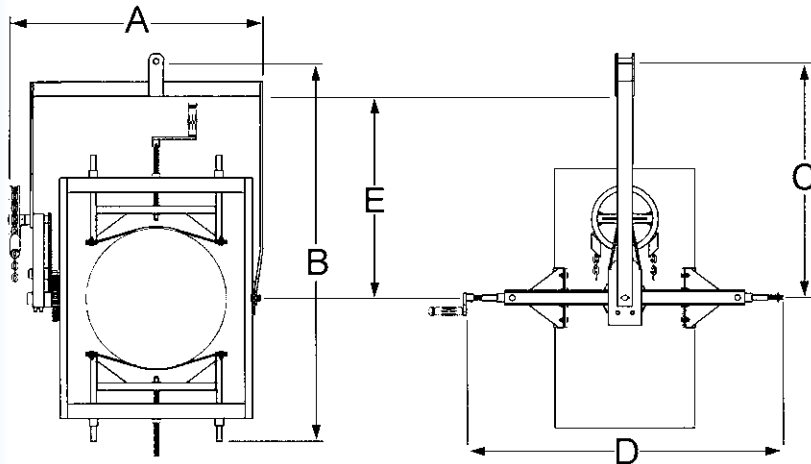

Model # 186	
Handles	15" to 23" Diameter (38.1 to 58.4 cm)
Dimension A	34.375" (87.3 cm)
Dimension B	48.125" (122.2 cm)
Dimension C	28.75" (73 cm)
Dimension D	Drum diameter + 20" (50.8 cm)
Dimension E	24.5" (62.2 cm)

Morse Adjusto-Karrier ships assembled in a carton.
Domestic ship dimensions:
L48" W36" H8" (122 x 92 x 20 cm)
Domestic ship weight is approximately 120 Lb. (55 kg).

Tilt Control Options

Standard tilt control is a chain wheel and a 12' (366 cm) pull-chain loop with 6' (183 cm) drop for high level pouring.

We recommend **Option # 3900i-P MORStop Tilt-Brake** factory installed on your Kontrol-Karrier to automatically hold the drum tilt angle.

Kit # 3900-P is the MORStop Tilt-Brake Kit for field installation.

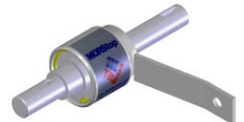

Option X02-186
9" (22.9 cm) Hand Crank

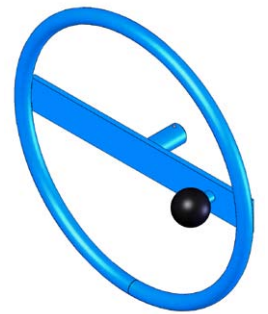

Option X03-186
16" (40.6 cm) Hand Wheel