

# ADVANTAGE

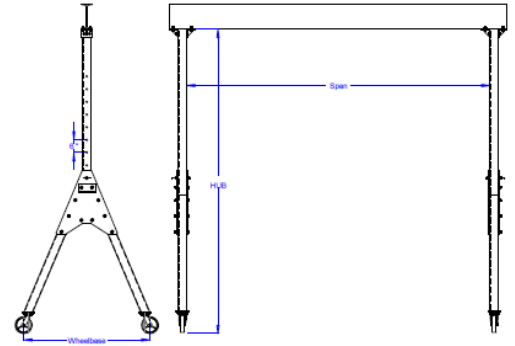
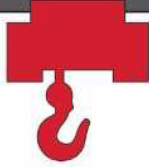

## AG-Series Adjustable Aluminum Gantry Crane 1/2 Ton - 2 Ton Capacity 8 to 12 ft. HUB

Capacity (Pounds)	Model	Span	Hub	Beam Height	Flange Width	Caster Diameter	Unit Weight
1,000	AG1/2-812	8'	8' to 12'	6"	3-3/8"	8"	336
1,000	AG1/2-1012	10'	8' to 12'	6"	3-3/8"	8"	344
1,000	AG1/2-1212	12'	8' to 12'	6"	3-3/8"	8"	353
1,000	AG1/2-1612	16'	8' to 12'	8"	4"	8"	408
2,000	AG1-812	8'	8' to 12'	6"	3-3/8"	8"	347
2,000	AG1-1012	10'	8' to 12'	8"	4"	8"	369
2,000	AG1-1212	12'	8' to 12'	8"	4"	8"	381
2,000	AG1-1612	16'	8' to 12'	10"	4-5/8"	8"	450
2,000	AG1-1812	18'	8' to 12'	12"	5"	8"	520
2,000	AG1-2012	20'	8' to 12'	12"	5"	8"	543
4,000	AG2-812	8'	8' to 12'	8"	4"	8"	451
4,000	AG2-1012	10'	8' to 12'	10"	4-5/8"	8"	493
4,000	AG2-1212	12'	8' to 12'	12"	5"	8"	547
4,000	AG2-1612	16'	8' to 12'	12"	5"	8"	593

### NOTE:

- Includes (4) polyurethane swivel casters, (2) with brakes and swivel locks.
- Standard wheel base on units above 5'-0".

### Accessories:

**TG** Tagline Kits - Steel Brackets

**Full Pneumatic Casters**—Set of (4) Swivel Casters (2) with brakes and locks. (Adds 12 in. approximately to height)

1/2 Ton Single Wheel 16 in.

1 Ton Single Wheel 16 in.

2 Ton Dual Wheel 16 in.

**LP** Lever Pullers with brackets for assisting height adjustment.

Set of 2 pullers and brackets

